

## Facilities Design

RON YOUNG AND BARRY STEEVENS

### Building and equipping a parabone swingline parlor

The milking parlor is one of the most important components of a modern pasture-based dairy. It is where the harvested forage crop is converted to the marketable product — milk.

The basic philosophy of most graziers carries over to the milking parlor. They want a facility that is inexpensive, very efficient and can be updated or improved as cash flow permits. Bottom line, most producers want a parlor large enough to allow them to complete each milking in 1 to 1½ hours.

Proper planning is imperative when locating and designing a parlor that rounds out an efficient dairy-grazing enterprise. In addition, producers must consider the guidelines and regulations of the Department of Natural Resources (DNR) and the State Milk Board. Use the following resources in the planning process:

- Your local University Outreach and Extension center
- USDA Natural Resources Conservation Service
- Missouri State Milk Board, (573) 751-3830
- Milk Marketing Fieldmen
- *The Missouri State Milk Board Informational Guide for Construction and Reconstruction of Milking Facilities*
- Milk Parlor at the University of Missouri Southwest Research Center, Mt. Vernon, Missouri
- Other dairy producers
- Equipment dealers
- Your county health department

One area that will receive only limited discussion in this chapter is site location for the milk parlor. However, choosing the site is a crucial step for efficiency, and you must follow DNR guidelines. Producers should select sites that will minimize costs while meeting DNR requirements for animal waste and parlor effluent. When restrooms are



Figure 11.1. View of a 7-foot-wide cow platform in a parabone swingline parlor with 26 inches allotted for each cow.



Figure 11.2. Interior of the tank room of a swingline parlor.

included in construction, county health departments will have to be contacted for site evaluation and to specify approved disposal methods. For efficiency of the pasture-based dairy operation, other site considerations must include cow travel from the paddocks to the parlor and any problems that could be caused by mixing animal and vehicular traffic.

For discussion purposes, design and construction of milk parlors will be based on experiences with Missouri pasture-based dairies over the past six years. The parlor of choice for these dairy producers has been the parabone parlor (Figures 11.1, 11.2 and 11.3), where the cows stand at a 70-degree

angle and the cluster (milking-claw assembly) is attached to the udder from the rear. Most of the units have high milklines and the cluster is swung from side to side. We will discuss the parabone parlor using the plans of the Southwest Research Center's double-10 parabone swingline parlor.

The parlor is unlike many of the early parlors that were constructed using the New Zealand-style milk shed with curtains for inclement weather. These parlors presented problems in Missouri because of our more severe winters. The parlor is constructed with an insulated wood frame with a fiberglass panel interior. Radiant gas heat offers a comfortable work area during the winter months with no freeze-up problems on equipment.

The basic unit in Figure 11.4 consists of a 32-foot x 32-foot structure. Inside dimensions for the



Figure 11.3. View of the operator pit in a swingline parlor.

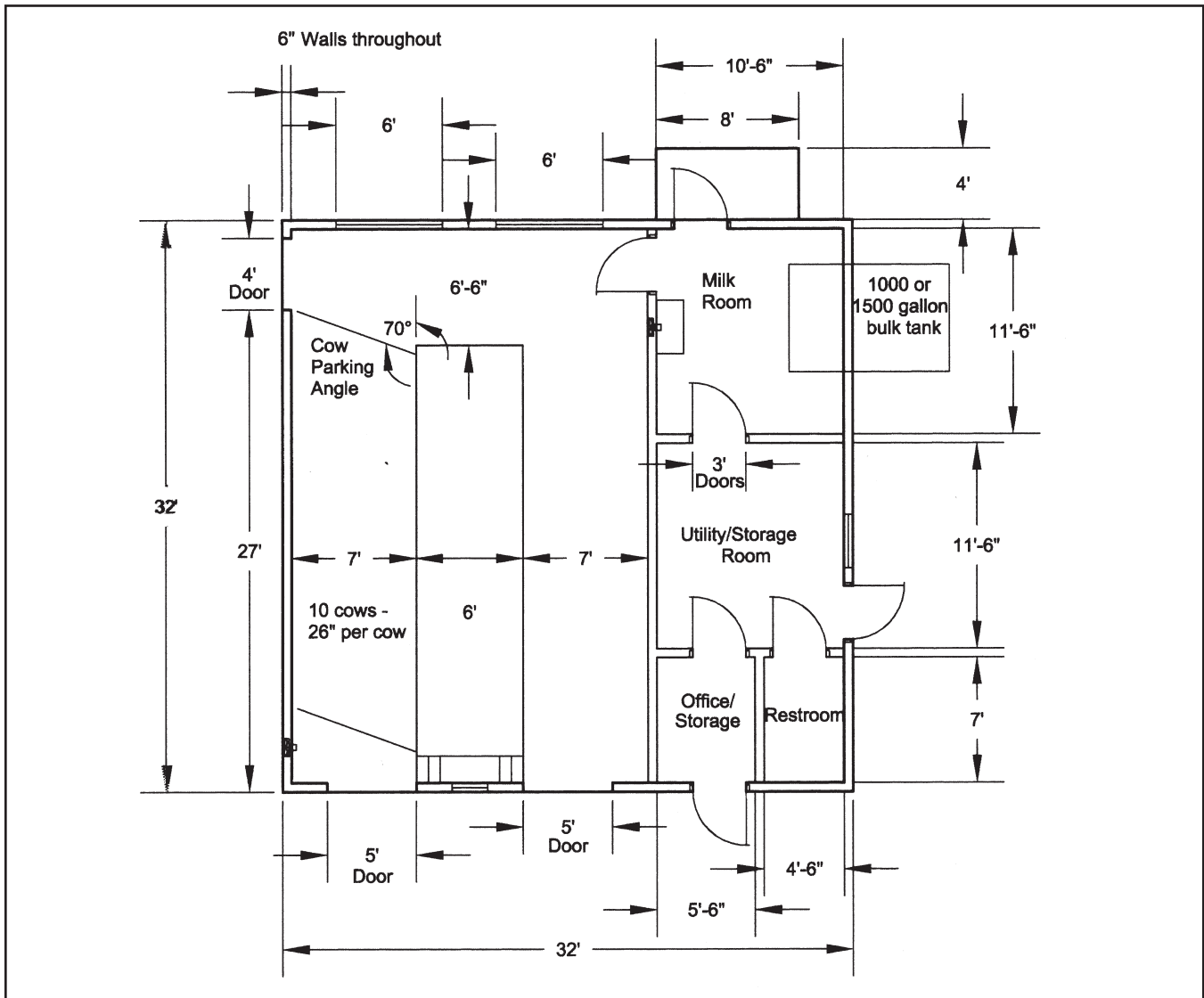

Figure 11.4. General layout of the basic unit of a parabone swingline parlor.

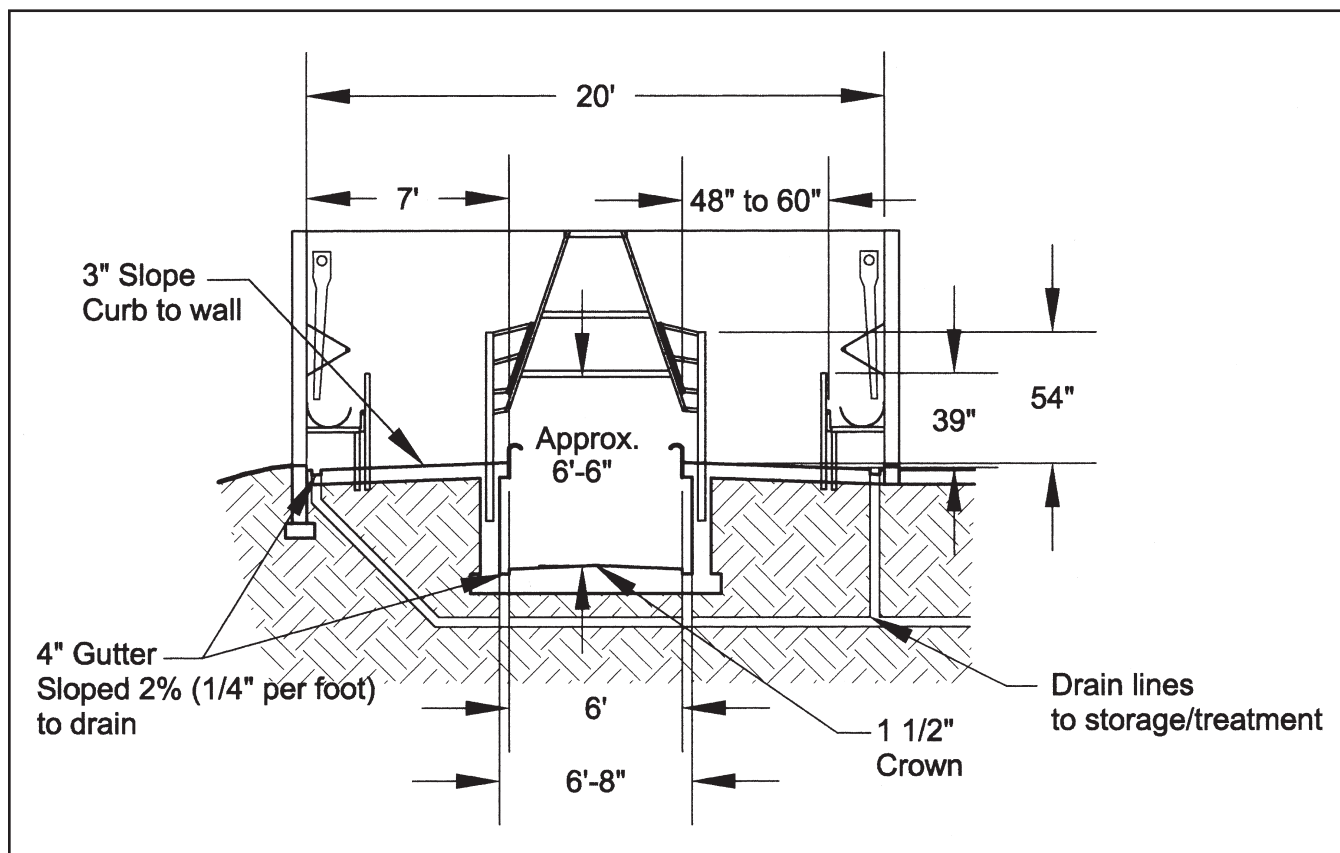

Figure 11.5. Layout of the inside of the parlor.

milking area are 20 feet x 31 feet. This provides a 7-foot cow platform and a 6-foot wide operator alley. The operator alley is 24 feet 6 inches long with 18-inch wide rear steps. These dimensions allow 21 feet 10 inches on the cow platform to secure the cows. This provides 26.2 inches per cow, which has proved adequate to hold 10 Holsteins. With Jerseys and mixed breeds, we often get two additional animals in the barn.

The entrance doors are 5-foot, industrial garage doors that give the cows full view of the parlor and reduce entrance time. The exit door is 4 feet wide; a larger door would be desirable if space permitted. There are no steps for the cows to negotiate. The holding pen has a 2 percent slope with a 1.5-inch rise to the cow platform. The exit lane has gates to make catching animals easy on operators and animals. There are two 3-foot x 6-foot hinged openings (with bird screening) at the front of the milking area for summer ventilation.

Figure 11.5 provides a better look at the inside of the milk parlor. The operator alley floor has a 1½-inch crown for easier cleaning and improved operator comfort. Cow platform height varies for the operator's comfort; it is usually set between 36

and 40 inches. For a rule of thumb, build the platform at about one half the height of the operator.

The stalls were fabricated on site from 1¼-inch or 1½-inch galvanized pipe. Two very important dimensions on the stalls for adjustment to different-sized animals are:

- Brisket rail to kick rail needs an adjustment of 48 to 60 inches (small breeds, 48 to 54 inches; large breeds, 54 to 60 inches).
- Top of the splash guard (rump rail) must be 9 to 10 inches outside the curb with a 7-foot cow platform. This extra length is needed for the larger breeds.

Figure 11.6 provides the dimensions needed to make a jig to assemble the A-frame for mounting the side rails. The A-frame spacing should be no more than 60 to 65 inches; three are required for a double-9 or double-10 parlor. The A-frame is not needed on the ends because the rails are welded to the supporting posts.

Recently, Missouri graziers have been installing feed troughs in the parlor. This represents a significant reduction in labor because it eliminates two outside feedings per day. Figures 11.7 and 11.8 give

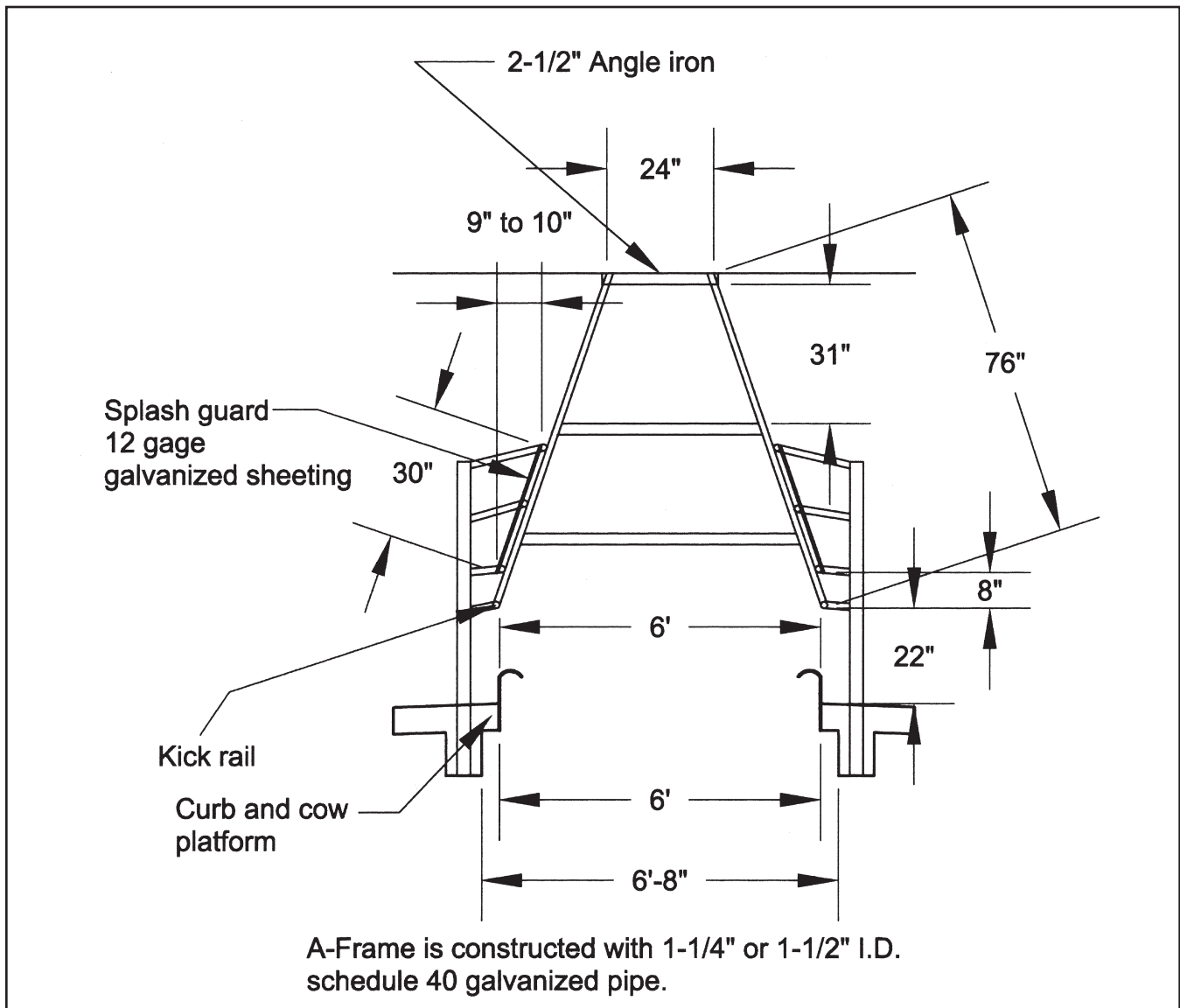

Figure 11.6. Layout of the A-frame in a parabone swingline parlor.

the dimensions for constructing the adjustable brisket rail and feed trough and spacing supporting posts. The feed trough is a halved 18-inch PVC sewer pipe. The sewer pipe comes in 13-foot lengths and is about  $\frac{1}{2}$  inch thick. A skill saw is used to cut the pipe. The pipe makes a very durable, inexpensive trough and costs approximately \$8.50 per foot. The delivery system is a flex auger system with adjustable rope pull dispensers. Grain can be delivered in increments of 1 to 15 lb per pull.

This discussion has centered on the double parabone parlor. The 21-foot-10-inch length of the stall area allows the cow platform to be level. However, as we add stalls (26 inches per stall), it may become necessary to construct the parlors on a 2 percent slope to maintain adequate slope on the

milking line. This should be determined by consulting the dealer installing the milking equipment. If there is more than 6 to 8 inches of variance in milking line height, front to rear, then consideration should be given to constructing the parlor on a 2 percent slope. All of the Missouri double-18 and double-20 parlors were sloped front to rear. This allows the producer to keep the milking line at a constant height, which prevents excessive lift on milk from the cluster. Otherwise, basic construction of the parlors are similar except for the milking equipment sizing, which is discussed later in this chapter.

The holding pen in the parabone parlor is similar to the pen in any other parlor. The herd has full view of the parlor entrance and interior, which can reduce entrance time. Most graziers determine

holding pen size by using 14 to 15 ft<sup>2</sup> per cow. For example: An 80-cow herd x 15 ft<sup>2</sup> per cow = 1,200 ft<sup>2</sup>, or a 30-foot x 40-foot holding pen. A producer may want to increase the size 10 to 15 percent for variance in herd size.

Missouri graziers have been pleased with the double parabone swingline parlors. Costs have been favorable but still represent a significant capital investment. Costs have ranged from \$26,000 to \$50,000 for double-10 parlors and \$60,000 to \$95,000 for double-18 or double-20 parlors. Graziers have provided personal labor and used pre-owned equipment to obtain these results. However, investments still range from \$500 to \$900 per cow on the smaller herds and most parlor costs range from \$2,500 to \$3,000 per stall.

The parabone parlors have accomplished one of the major goals of most graziers. They have signifi-

cantly reduced time in the parlor, in some cases by up to 4 hours a day. This improves quality of life by allowing the grazier to spend more time managing the herd and grass and still have time for family.

### Planning your milking system for the swingline type parlor

The milking system must help the pasture-based dairy producer rapidly milk the dairy herd as well as be cost-efficient. Graziers may be able to take advantage of available used milking equipment at a fraction of the cost of new; however, it needs to meet adequate standards for today's dairy cow.

The term "swingline" describes a simple, efficient New Zealand-style milking system. During the 1950s, the highline (swingline) parlor was common in Missouri. It can be described as a parlor

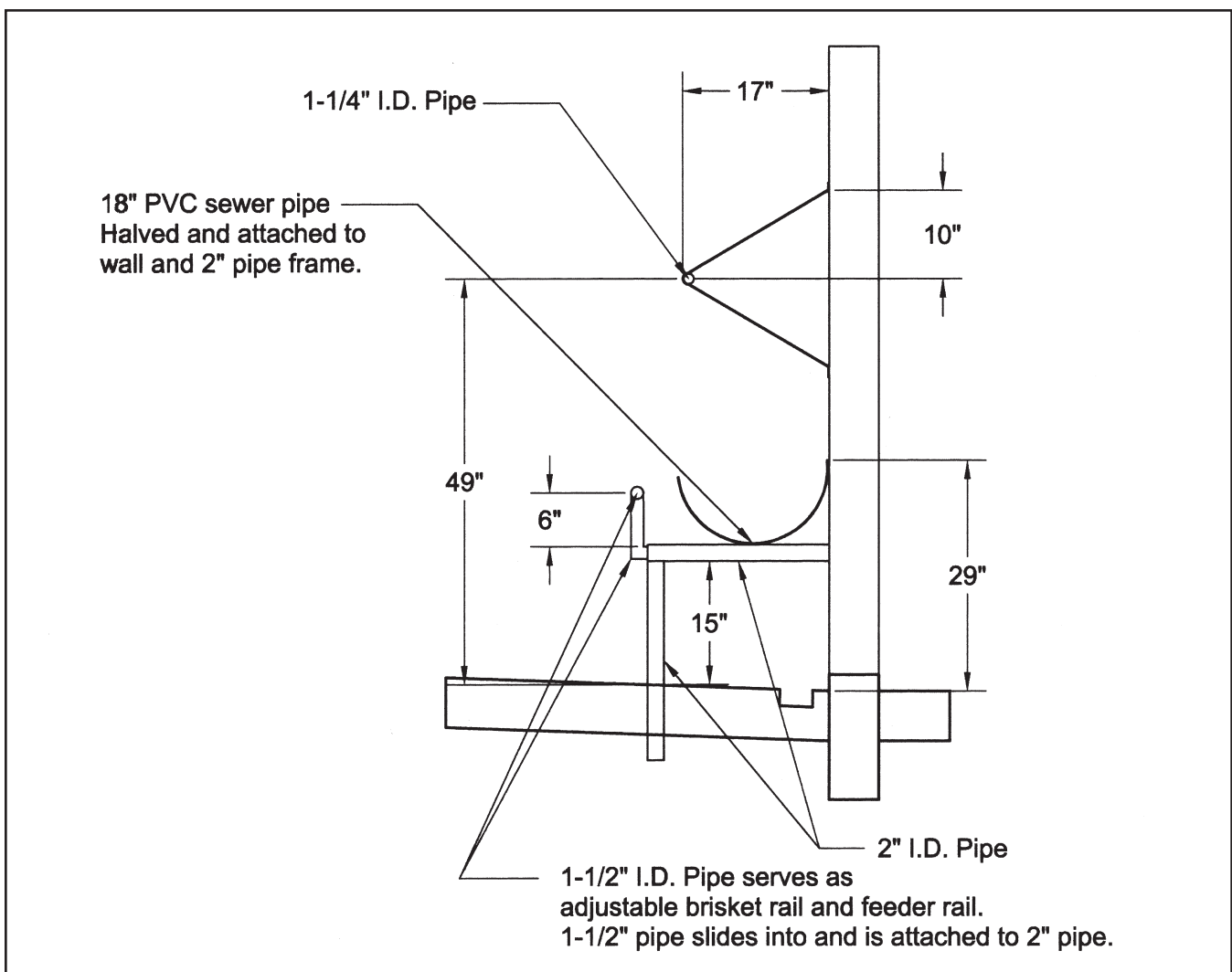

Figure 11.7. Layout of the adjustable brisquet rail and feed trough for a parabone swingline parlor.

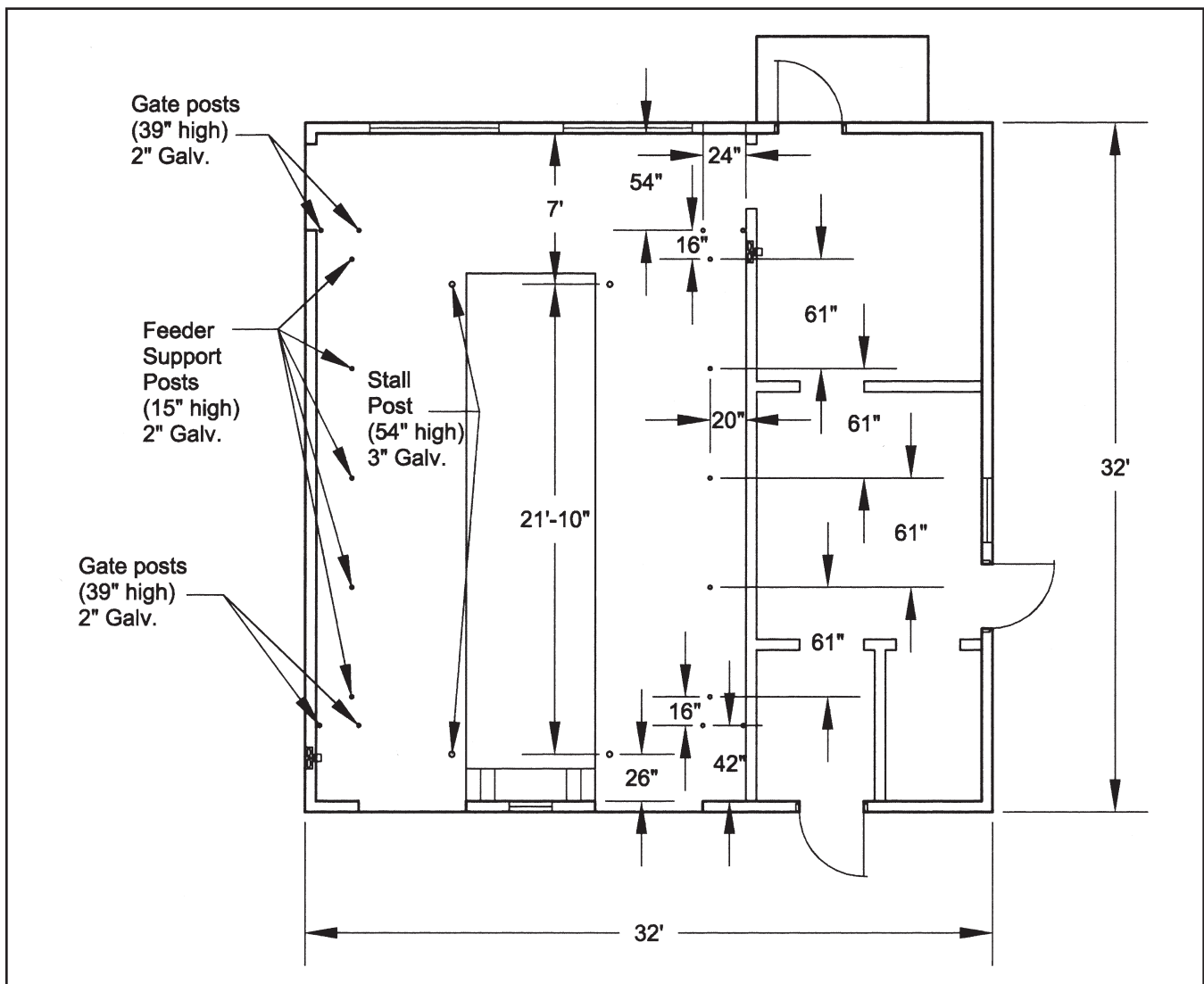

Figure 11.8. Spacing and sizes of the posts supporting the gates, stalls and feeders in a parabone swingline parlor.

where cows enter on both sides with each cluster shared between two stalls, one on each side.

As milk production per cow increased, these older systems were replaced with improved lowline milking systems that had a milking unit at each stall. The lowline was recognized as providing a more stable milking vacuum and faster milkout with less stress to the teat end. The reduction of the milking vacuum to 12½ inches mercury (Hg) and removal of the cow's milk with a lowline were not the only improvements. With the lowline came larger milklines, larger claws, more accurate air controllers and improved pulsation systems.

Research has shown that some of the factors that contribute to the spread of mastitis in dairy herds are milking infected udders with cyclic and irregular vacuum fluctuation.

An adequate swingline milking system operates with a higher vacuum setting (13½ to 15 inches Hg) and will have cyclic but not irregular vacuum fluctuations in the milking claw. Dairy cows can be milked efficiently with minimal stress to the udder as long as the swingline milking system is installed with adequate vacuum capacity and milkline size as well as a properly functioning air controller and pulsation system. Many high-producing herds are milked with a highline pipeline system in a stanchion dairy barn.

### Sizing the parlor and factors that affect cow throughput

Many graziers want milking chore time to last no more than two hours including setup and

cleanup. This translates into 1½ hours of milking time.

A number of factors affect parlor throughput, including production level, milking procedures, number of people milking, number of people standing in the way, stage of lactation and cow cleanliness.

Some general observations include:

- Each side will have three to four turns per hour.
- Two people can handle up to 32 clusters with no takeoffs and up to 40 clusters with takeoffs.
- One person can handle up to 14 to 16 clusters with no takeoffs and up to 20 clusters with takeoffs.
- An additional operator increases parlor throughput by 10 to 20 percent.
- Washing and drying of teats decreases parlor throughput by 20 percent.
- Slightly lower milk yield will result in nearly similar parlor throughput for a swingline as compared to a conventional parlor with one cluster for each stall.

With the assumption that it takes 15–20 minutes to turn each side, a double-10 swingline with 10 units can be expected to milk 60 to 80 cows per hour. This assumes a machine on time of 6–9 minutes for each cow. Field data from Missouri and Wisconsin for swingline parlors suggest about three turns per hour with a range of 2.5 to 4.7. Operator speed, availability of a crowd gate, and the number of operators in the pit all affect milking efficiency.

## Milking equipment

### Vacuum pump

A simple guideline for sizing the pump is as follows, where  $N$  = the number of units, and cubic feet per minute (CFM) is measured as free air (at 0 inches Hg):  $CFM = 35 + 3N + \text{air flow for special components}$ .

The estimate, 35, is required to cover operational requirements such as teat-cup application and unit falloffs. The falloff requirement is the largest, ranging from 22 to 50 CFM. The typical unit and pulsator requirement is 2 CFM.

Vacuum pump lubrication is related to pump type:

- Vane-type pumps require oil to seal the sliding vane against the housing. Large vane-type pumps may come with an oil reclaimer, which reduces the amount of oil used and discharged through the exhaust.
- Water ring pumps are lubricated and cooled with water. Water usage may be 1 to 3 gallons/minute. Water quality is important because hard water may deposit minerals on the moving parts.
- Lobed (blower) pumps are not lubricated except for the spindle bearings. These pumps run at very close tolerances. A trap with a filter must be installed before the vacuum intake to prevent the intake of milk residue into the pump. These pumps have a “clean” exhaust.

The exhaust of vacuum pumps, with the exception of water ring pumps, is quite hot, so the discharge pipe must be made of metal for some distance from the pump.

Vacuum pump capacity is about 10 CFM per horsepower for oil and lobed pumps and about 7.5 CFM per horsepower for water ring pumps (Table 11.1).

### Air line sizing

Vacuum air lines deliver air from the distribution tank to the pump. At the distribution tank, the air divides, and vacuum is provided to the milk receiver. Separate branches provide for a looped pulsator line. Proper sizing of vacuum lines exists when the vacuum drop between the end of the system (milkline) and the pump does not differ by

**Table 11.1. Number of milking units associated with vacuum pump capacity.**

Horsepower of motor	Oil or lobed pump		Water pump	
	Number of milking units	Pump capacity, CFM	Number of milking units	Pump capacity, CFM
5	1–5	50	1	37
7.5	6–12	75	2–6	56
10	13–20	100	7–12	75
15	21–35	150	13–24	112

Bray, 1992

more than 0.6 inch Hg. Minimum air-line sizing is provided in Table 11.2.

### Milkline sizing

The milkline must carry milk along with air without flooding during milking. This is known as stratified flow. An occasional falloff can result in a slug. Any condition of consistent flooding can be observed at the milk receiver. If there is flooding, milk will enter the milkline in spurts. Flooding should not occur during normal milking. A sensitive electronic recorder can determine if you have flooding. The milkline vacuum at the end of the line should not drop more than 0.6 inch Hg.

Table 11.3 gives milkline size with number of recommended clusters (Mein and Reinemann, 1993). Care must be taken when installing used equipment to ensure that the milkline is adequately sized and installed with the appropriate slope. This is necessary to avoid slugging and foaming of the milk during peak milk yield in the spring.

### Pulsators and pulsation pipelines

The general guidelines for pulsator pipelines are as follows: 2 inches for 1 to 14 units, and 3 inches for 15 or more units.

Because of consistency, electric pulsation is most widely used. Pulsation milk:rest (M:R) ratios normally used are 50:50 to 70:30. Many of the new milking systems are set at with a M:R ratio of 60:40 to 70:30 at 60 pulsations per minute. Cows milked at the wider milk:rest ratios tend to milk more rapidly. Alternating pulsation allows the milk to flow more evenly to the milkline.

### Vacuum controller

A properly operating controller maintains a constant vacuum by opening or closing air admission to the system. Modern-style controllers are sensitive to changes as small as 0.2 inch Hg. The capacity of the controller should be greater than the pump capacity. It is important that they function in a relatively dust-free environment. Consult the dealer or manufacturer for proper installation.

**Table 11.2. Minimum pipe sizes (inches I.D.) for the main airline of a milking system.**

Vacuum pump capacity (CFM)	Approximate length of main airline (feet)				
	10	20	40	60	80
50	2	2	3	3	3
70	3	3	3	3	3
100	3	3	3	3	3
150	4	4	4	4	4

Mein and Reinemann, 1993

Notes: Main airline is defined as the pipeline between the vacuum pump and the sanitary trap near the receiver. Calculations are based upon a maximum drop of 0.6 inch Hg between the receiver and the vacuum pump. Table includes allowance for the equivalent length (feet of straight pipe) of one distribution tank, one sanitary trap and 8 elbows. Keep in mind the maximum airflow is from the regulator to the vacuum pump. If the regulator is on a branch pipe, use the full pipe size indicated above.

**Table 11.3. Recommended number of clusters on a swingline milk pipeline.**

Milkline size (inches)	Milkline slope (percent)				
	0.8	1	1.2	1.5	2
2.0	2	3	3	4	5
2.5	6	6	7	9	10
3.0	11	13	14	16	19

Mein and Reinemann, 1993

### Milking cluster

Most claws today are of adequate size, but some are too heavy for a swingline dairy. To determine milking end point, you should be able to see the milk flow. For milking between the rear legs, new generic claws have been designed so that the window on a barrel is facing the operator. Most claws have a 5/8-inch milk hose. Keep the milk hose to the minimum length to minimize the vacuum drop when lifting milk to the milkline. Vacuum drop in the claw on a swingline will normally be 2 to 3 inches Hg. If DHI meters are attached, the drop is increased, which may result in slow milking. It may be necessary to increase the milking vacuum 1 or more inches of Hg on test day.

Be sure to set the vacuum level back to normal when the milk meters are disconnected.

### Cleaning

Other items in a swingline parlor include wash lines, air injector, wash tank, hot water heater and an optional plate cooler.

The installation of a plate cooler to help cool your milk will require a larger milk pump (1½ to 2 hp) to adequately pump the wash water from the receiver. Be sure to consult with your dealer.

The water heater needs to be able to supply 165-degree F water. Some of the new energy-efficient water heaters are set to a maximum of 145 degrees F, which is not adequate for proper cleaning. If water hardness (calcium and magnesium) is more than 10 grains hardness, a water softener is highly recommended. Otherwise, the minerals tie up the soap and you will not be able to adequately clean the system.

Cleaning the system is important for producing high-quality milk. Cleaning should begin as soon as milking ends. To clean:

- Rinse with lukewarm water (95 to 100 degrees F).
- Wash with 160-degree F water for 8 to 10 minutes. At the end of washing, water temperature should not drop below 110 degrees F or milk-fat will redeposit.
- Follow with an acid rinse with the water at 95 to 100 degrees F.

### Bulk tank

The bulk tank should be sized to accommodate five milkings with pickups scheduled for every other day. A 60-cow dairy should plan for a 1,000-gallon tank, and for a 100-cow herd, use a 1,500-gallon tank. When buying a used tank, be aware of the change away from R12 refrigerant.

### Buying used equipment

Plan your system to know what is needed. This may involve working with your local dealer.

Things to be aware of:

- **Vacuum pump.** Pump should meet 90 percent of manufacturer's rating — install new belts and rubber connections.
- **Air controller.** Clean and replace all rubber parts.
- **Milking claw.** Check for bent ferrules, make sure air vent is open, and avoid excessively heavy clusters.
- **Pulsators.** Clean and replace all rubber parts and gaskets. Have a dealer with an instrument check for proper function when installed.
- **Milkline:** Make sure line is adequately sloped (1–2%).

### Installation

Conduct a 0-hour system check. Check every pulsator for proper function. Run the wash cycle to observe for proper cleaning action. And last, *conduct a stray voltage check at milking time.* The AC voltage

reading in the parlor against an isolated ground should be less than 0.5 volt.

### Managing heat stress

The grazing dairy cow produces considerable body heat through fermentation and metabolism of feed and through muscle activity during grazing. Research data suggests a lactating cow producing 60 pounds of milk will produce more than 3,000 BTUs (British thermal units) of heat per hour. This heat load is to the cow's advantage in the winter but can contribute significantly to heat stress in the summer.

At 75 degrees F and 65 percent humidity (temperature humidity index of 72 in Table 11.4), a cow begins to experience mild heat stress. As the temperature exceeds 80 degrees, the cow begins to breathe more rapidly and milk production declines.

A dairy cow dissipates heat in several ways. Body heat can be conducted to the cool earth in a mud hole or radiated to the night sky. A breeze moving over the cow's body cools by convection. Cows sweat through their skin and rely mainly on evaporation for dissipating heat on a hot summer's day. They also eliminate large amounts of heat through respiration. As temperature rises in still air, the cow increases its respiration from a normal rate of 35 breaths per minute to as many as 120 breaths per minute with its tongue hanging out. Under humid conditions this method becomes less efficient and the cow is in distress. Rapid respiration increases the heat load from the action of muscles associated with breathing. The maintenance requirement of a heat-stressed cow can increase by more than 25 percent, and feed intake decreases, resulting in a 20 to 30 percent decline in milk production.

### Management strategies

#### Shade

Shade is the easiest and most obvious way to provide relief for a heat-stressed cow. Direct sunlight adds a considerable heat load to a cow. Research indicates that the black globe temperature (simulating a cow without shade) increases 18 to 25 percent in direct sunlight (Table 11.5).

Shade trees provide a cool place for cows to rest, but as herds increase in size, the trees are killed. Allowing cows to cool themselves in mud holes requires more time to clean the cows at milk-

Table 11.4. Temperature humidity index for dairy cows.

		Relative humidity (%)																				
		5	10	15	20	25	30	35	40	45	50	55	60	65	70	75	80	85	90	95	100	
Degrees (F)	70	64	64	64	65	65	65	66	66	66	67	67	67	68	68	68	69	69	69	70	70	
	71	64	65	65	65	66	66	66	67	67	67	68	68	68	69	69	70	70	70	71	71	
	72	65	65	65	66	66	67	67	67	68	68	69	69	69	70	70	70	71	71	71	72	72
	73	65	66	66	66	67	67	68	68	68	69	69	70	70	71	71	71	72	72	72	73	73
	74	66	66	67	67	67	68	68	69	69	70	70	70	71	71	71	72	72	73	73	74	74
	75	66	67	67	68	68	68	69	69	70	70	71	71	72	72	73	73	74	74	74	75	75
	76	67	67	68	68	69	69	70	70	71	71	72	72	73	73	74	74	75	75	76	76	76
	77	67	68	68	69	69	70	70	71	71	72	72	73	73	74	74	75	75	76	76	77	77
	78	68	68	69	69	70	70	71	71	72	72	73	73	74	74	75	75	76	76	77	77	78
	79	68	69	69	70	70	71	71	72	73	73	74	74	75	75	76	76	77	77	78	78	79
	80	69	69	70	70	71	72	72	73	73	74	75	75	76	76	77	78	78	79	79	80	80
	81	69	70	70	71	72	72	73	73	74	75	75	76	77	77	78	78	79	80	80	81	81
	82	69	70	71	71	72	73	73	74	75	75	76	77	77	78	79	79	80	81	81	82	82
	83	70	71	71	72	73	73	74	75	75	76	77	78	78	79	80	80	81	82	82	83	83
	84	70	71	72	73	73	74	75	75	76	77	78	78	79	80	80	81	82	83	83	84	84
	85	71	72	72	73	74	75	75	76	77	78	78	79	80	81	81	82	83	84	84	85	85
	86	71	72	73	74	74	75	76	77	78	78	79	80	81	81	82	83	84	84	85	86	86
	87	72	73	73	74	75	76	77	77	78	79	80	81	81	82	83	84	85	85	86	87	87
	88	72	73	74	75	76	76	77	78	79	80	81	81	82	83	84	85	86	86	87	88	88
	89	73	74	75	75	76	77	78	79	80	80	81	82	83	84	85	86	86	87	88	89	89
90	73	74	75	76	77	78	79	79	80	81	82	83	84	85	86	86	87	88	89	90	90	
91	74	75	76	76	77	78	79	80	81	82	83	84	85	86	86	87	88	89	90	91	91	
92	74	75	76	77	78	79	80	81	82	83	84	85	85	86	87	88	89	90	91	92	92	
93	75	76	77	78	79	80	80	81	82	83	84	85	86	87	88	89	90	91	92	93	93	
94	75	76	77	78	79	80	81	82	83	84	85	86	87	88	89	90	91	92	93	94	94	
95	76	77	78	79	80	81	82	83	84	85	86	87	88	89	90	91	92	93	94	95	95	
96	76	77	78	79	80	81	82	83	85	86	87	88	89	90	91	92	93	94	95	96	96	
97	77	78	79	80	81	82	83	84	85	86	87	88	89	91	92	93	94	95	96	97	97	
98	77	78	79	80	82	83	84	85	86	87	88	89	90	91	93	94	95	96	97	98	98	
99	78	79	80	81	82	83	84	85	87	88	89	90	91	92	93	94	96	97	98	99	99	
100	78	79	80	82	83	84	85	86	87	88	90	91	92	93	94	95	97	98	99	100	100	

ing and increases the probability of mastitis.

Several grass-based dairies have used portable shades in the pasture. A nylon-mesh shade cloth is fastened to a lightweight pipe frame. The mesh reduces direct sunlight by 80 to 90 percent. Shades should be sized to provide 35 to 45 square feet of shade per cow.

The pasture-based dairy at the University of Missouri Southwest Research Center has used portable shades effectively for several grazing seasons. Experience has shown that as temperatures approach 80 to 85 degrees F in the Midwest, lactating dairy cows must have shade (see Table 11.4).

The absence of both shade and windbreaks at the Southwest Research Center led to the development of a portable, dual-function shade and windbreak. It consists of an inverted trapezoid (shorter side down) constructed from 1-inch schedule 40 steel pipe. A 12 x 24 foot polyethylene “cow shade” made of 80 percent shade material is secured to the frame by polyethylene rope through grommets on 6-inch centers (Figure 11.9).

This structure provides 288 square feet of shade, enough for six to eight lactating dairy cows.



Figure 11.9. Cows use a dual-function portable shade/windbreak for shade in summer. Turned on its side and fastened to the ground, the structure provides shelter from cold winds in winter.

An all-terrain vehicle is used to tow the cow shades from one grazing paddock to another. During the winter months, the shades are tilted on one side, facing north, to provide shelter from the wind. They provide downwind protection for about 100 feet. Each structure must be secured by stakes, and

Table 11.5. Managing heat stress in lactating dairy cows.

Measurement	Trial one <sup>a</sup>			Trial two <sup>b</sup>		
	Shade	No shade	% change	Shade	No shade	% change
Black globe temp., °F	86.2	101.8	-18.1	84.4	105.8	-25.3
Rectal temp., °F	101.7	103.3	-1.6	102.6	105.4	-2.7
Respirations/min.	78	115	-47.4	83	133	-60.2
Daily feed intake, lb				45.6	37.0	23.2
Daily milk yield, lb				42.8	37.5	14.1

<sup>a</sup> Adapted from Collier et al., 1981. *Journal of Dairy Science* 64:844.  
<sup>b</sup> Adapted from Scheider et al., 1984. *Journal of Dairy Science* 67:2546.  
 Source: Joe West, University of Georgia.

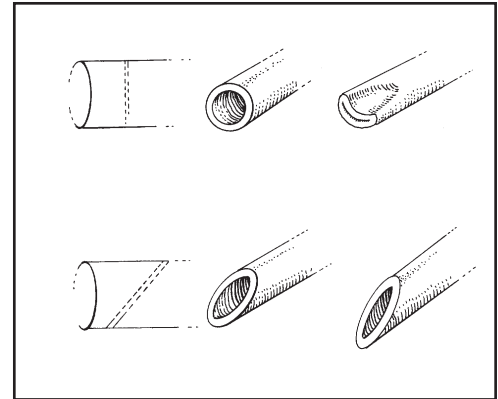

Figure 11.10. Top: Brace A in Figure 11.11 has ends cut square and smashed with a hammer to form a saddle as shown. Bottom: Other braces are cut on an angle and flattened to an oval to fit.

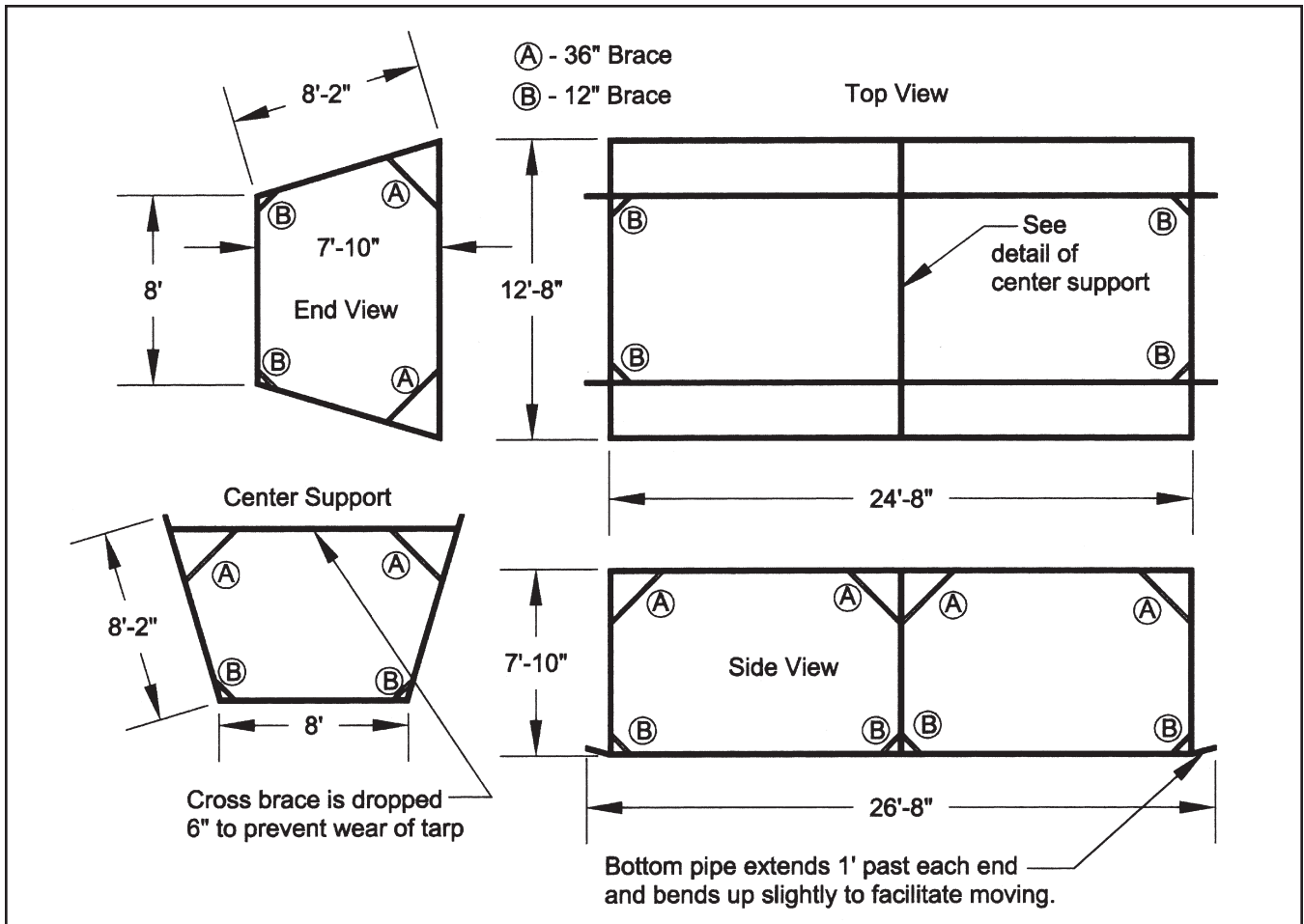

Figure 11.11. Measurements for construction of trapezoid-shaped portable shade/windbreak.

an electric fence installed nearby prevents damage to the shade itself. See Figures 11.10 and 11.11 for construction details.

### Water

Water makes up 85 percent of the content of milk. As environmental temperature rises, the cow's water requirement increases by more than 50 percent. Water intake can increase from 20–25 gallons/day to 35–40 gallons/day as temperature increases from 65 to 85 degrees. Cows will receive a portion of their water requirement from succulent pasture, but additional water should be available. Cool water should be within 100 to 300 feet of where cows are resting.

### Cooling in the holding pen

Cows will benefit from a roof over the holding pen. The roof must have an adequate opening at the top to allow heat to escape when the cows are waiting to be milked. Considering that each cow gives off 3,000 to 4,000 BTUs/hour, the heat-generating capacity of 50 cows is equivalent to a 200,000-BTU furnace. Stated another way, each cow generates the heat equivalent of sixteen 100-watt light bulbs, which means that a herd of 50 cows in a holding pen generates as much heat as 800 light bulbs.

Fans and sprinklers in the holding pen can help cool cows through evaporation (Figure 11.12). Placement of two or three 3-foot-diameter fans directed away from the milking pit will help

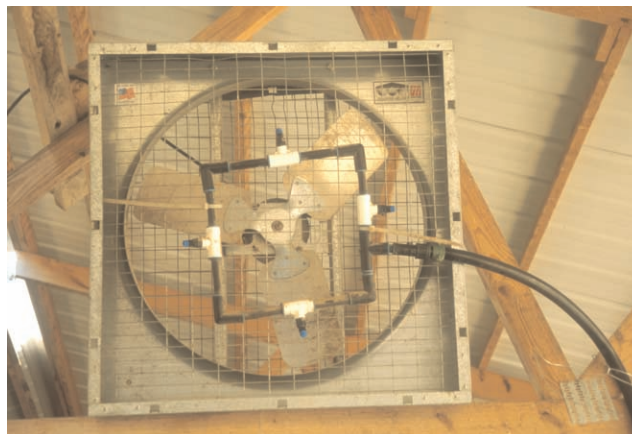

**Figure 11.12.** Fans and sprinklers in the holding pen can help cool cows through evaporation.

remove heat as cows are waiting to be milked. A 3-foot fan will move air about 30 feet. Sprinklers can be controlled manually from the pit. The sprinkler should thoroughly wet the skin of the cow and then be shut off. Cows should not have water dripping off their sides as they enter the parlor.

### References

- Bray, D.R. 1992. "Milking system evaluation and maintenance." In *Proceedings Large Herd Management Conference*. 507–516. Gainesville, Fla.
- Mein, G., and D. Reinemann. 1993. "Sizing milklines: Recent research results and recommendations." In *National Mastitis Council 1993 Annual Meeting Proceedings*. 111–115.